

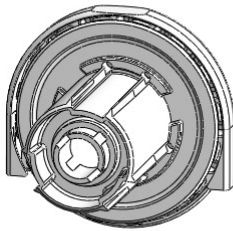

INDUSTRIES INC.

C16 clutch components

CIERA Industries Inc. a USA based company is introducing **new clutch** for roller shades and folding shades.



Clutch

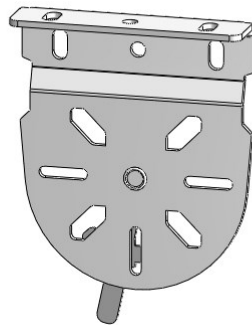

Clutch Bracket With Hook

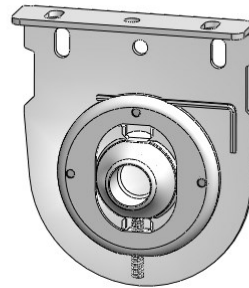

Adjustable Height Idler Bracket

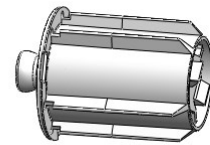

Spring Loaded Idler

Features and Benefits:

- Patented clutch mechanism allow for smooth and even shade operation
- Torsion spring configuration in the clutch eliminates “dead spots” in clutch operation
- Clutch is firmly secured to the bracket with a swiveling hook
- Unevenly install shade can be easily leveled by adjusting idler position 3/8”
- Hardware is designed to maintain 5/8” light gap on either side of the shade
- Brackets are assembled as ceiling mounts as well as left and right side wall mounts
- Maximum roll-up diameter - 3 3/4”
- Shape of the clutch allow the stop ball on the bead chain rest evenly on the bottom of the clutch with out being wedged between the plastic
- Material selection and hardware design make the shade operation quiet
- Spherical shape of the idler shaft allow easy shade installation and minimal friction during operation

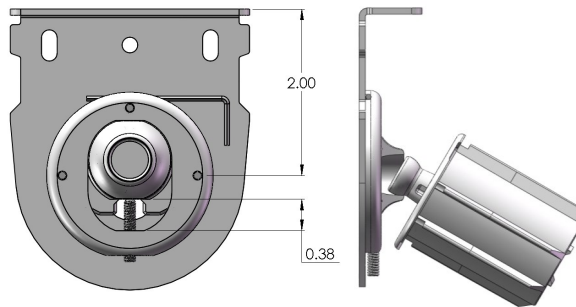

Idler End Installation

Innovative collapsible idler allows for easy, one person installation by resting ball-end of the spring loaded shaft on the idler bracket while rotating clutch end of the shade into clutch bracket.

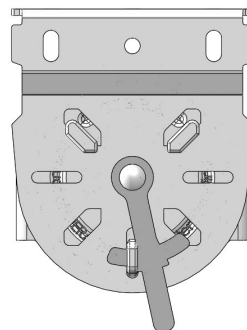

Clutch End Installation

Patented hardware allows the self aligning clutch hooks rest on the bracket and the swivel hook locks the clutch in place by sliding into the bridge on the back side of the clutch

CIERA Industries Inc.
Valencia CA

661-263-8505 Phone
661-263-8305 Fax
sales@cierainc.com E-mail
www.cierainc.com Website